

FOUR (4) M4X20 mm  
FLAT HEAD SCREWS

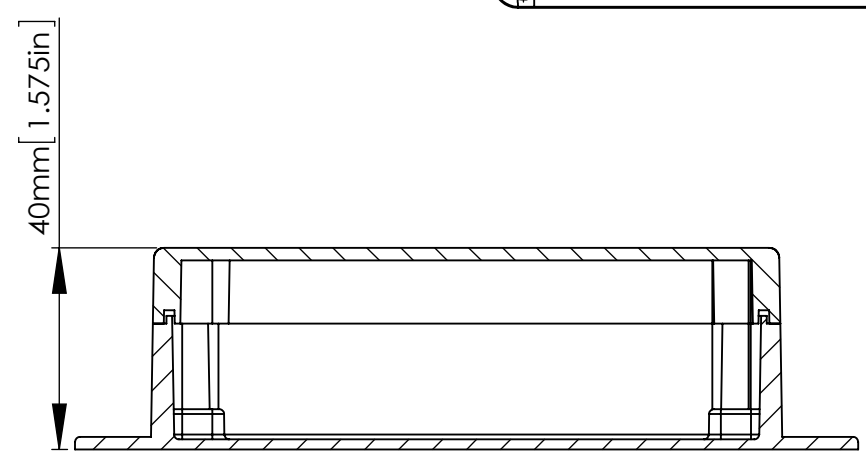
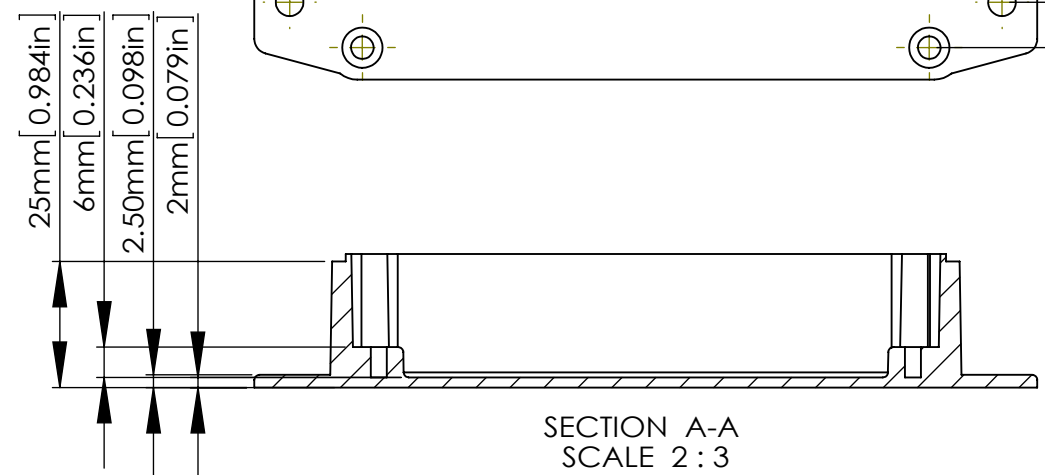
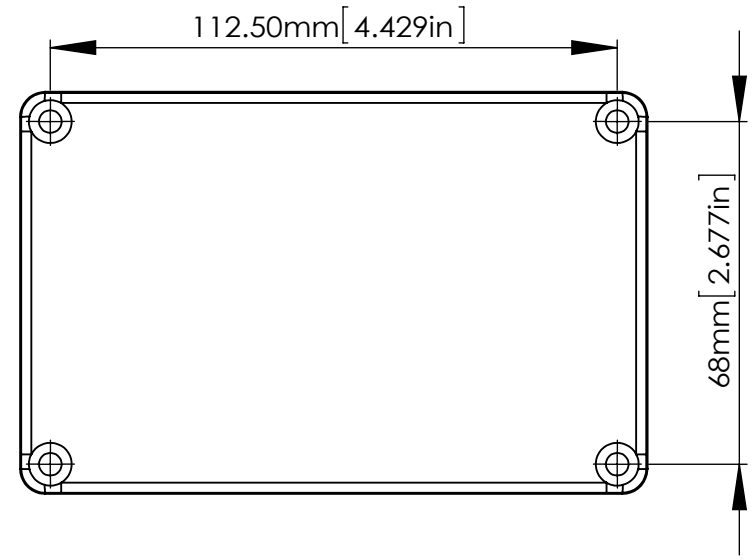
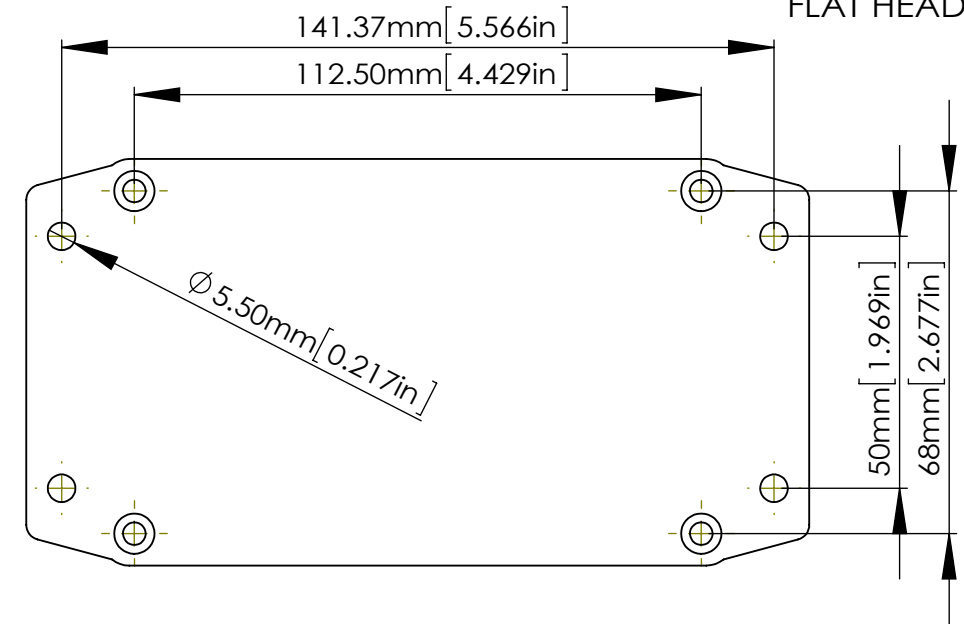

According to ISO 2768-m	
Measuring DIM=L	Tolerances
0.5<L<=3.0mm	±0.1mm
3.0<L<=6.0 mm	±0.1mm
6.0<L<=30.0 mm	±0.2mm
30.0<L<=120.0 mm	±0.3mm
120.0<L<=400.0 mm	±0.5mm
400.0<L<=1000.0 mm	±0.8mm

宣又實業有限公司  
GAINTA INDUSTRIES LTD.

繪圖 DRA'D BY  
JACKY

日期 DATE  
2024/01/03

材質 MATE.  
ALUMINIUM ALOOY ADC-12

圖名TITLE:  
G107MF-IP67

圖號DWG NO:

版次REVISID:  
B

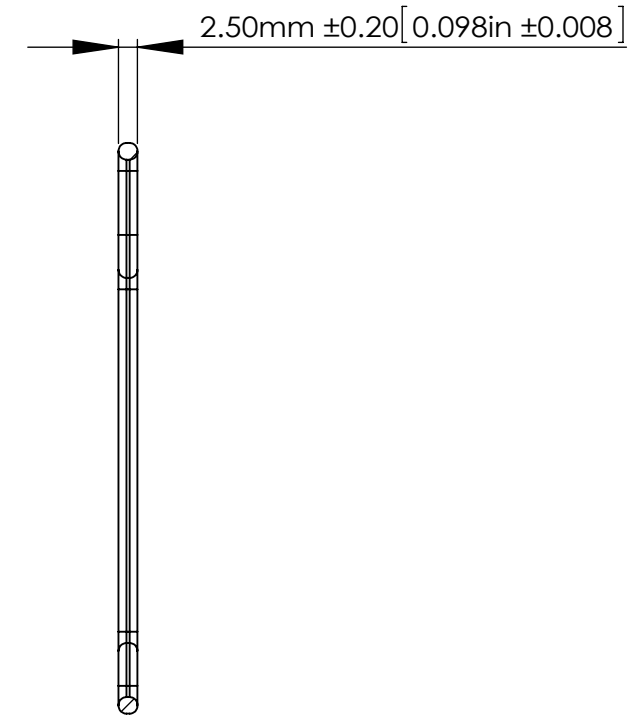
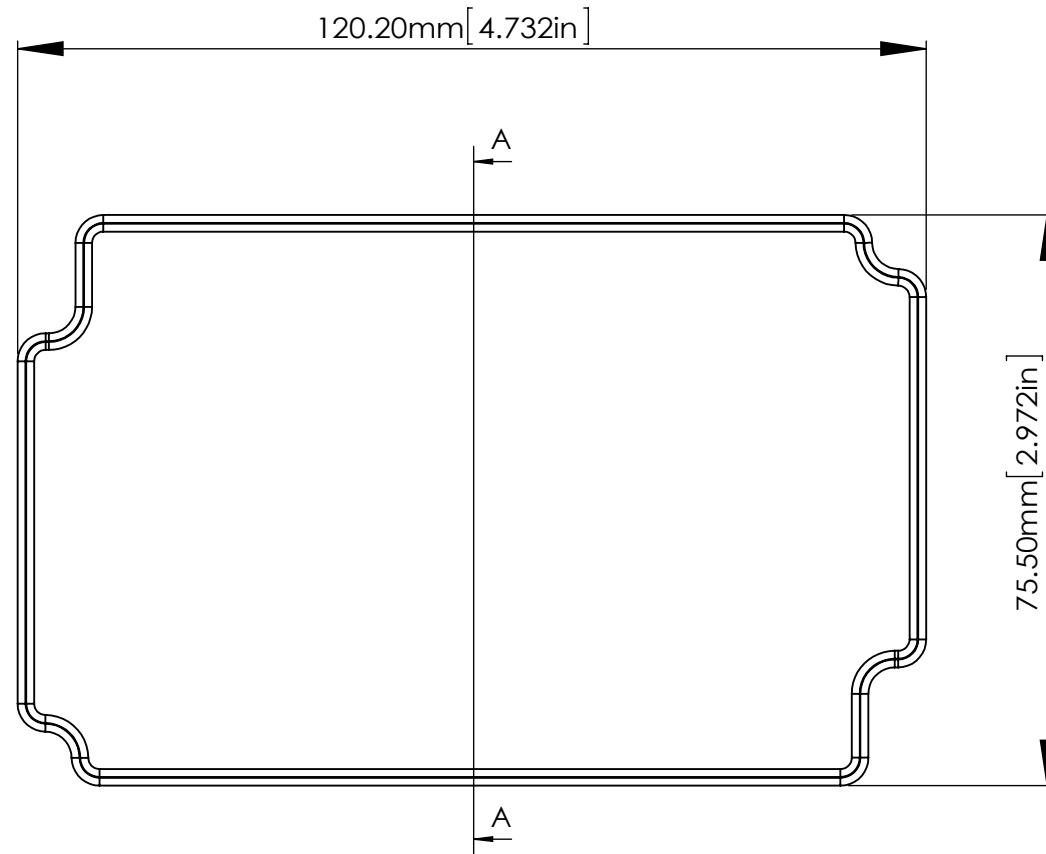

SECTION A-A  
SCALE 1 : 1

According to ISO 2768-m	
Measuring DIM=L	Tolerances
0.5<L<=3.0mm	±0.1mm
3.0<L<=6.0 mm	±0.1mm
6.0<L<=30.0 mm	±0.2mm
30.0<L<=120.0 mm	±0.3mm
120.0<L<=400.0 mm	±0.5mm
400.0<L<=1000.0 mm	±0.8mm

宣又實業有限公司  
GAINTA INDUSTRIES LTD.

繪圖

DRA'D BY  
JACKY

日期

DATE

2023/12/01

材質

MATE.

EPDM

圖名TITLE:

G107SEAL/G108SEAL

圖號DWG NO:

版次REVISED:

**B**